

# SECTION 4 - FUEL/LUBRICATION/COOLING

---

---

## TABLE OF CONTENTS

---

Carburetor Specifications .....	4-2
Carburetor Schematic .....	4-2
Carburetor .....	4-3
Cleaning and Inspecting Carburetor.....	4-6
Throttle Cable Free-Play .....	4-6
Engine RPM (Idle).....	4-7
Gas Tank .....	4-7
Fuel Valve .....	4-8
Gas/Vent Hoses .....	4-8
Oil Flow Chart .....	4-9
Oil Filter/Oil Pump .....	4-10
Testing Oil Pump Pressure.....	4-10
Oil Tank .....	4-11
Liquid Cooling System .....	4-12
Radiator.....	4-12
Hoses/Thermostat.....	4-13
Fan .....	4-14
Servicing Water Pump .....	4-14
Engine Coolant Temperature Switch.....	4-17
Cooling Fan Thermo-Switch.....	4-17

# Carburetor Specifications

ITEM	
Type	Mikuni BSR36
Main Jet	130
Pilot Jet	22.5
Pilot Screw (turns)	2 1/4
Needle Jet	P-OM
Jet Needle	5E26-1
Idle RPM	1250-1350
Starter Jet	60
Float Arm Height	13 mm (0.5 in.)
Throttle Cable Free-Play (at lever)	3-6 mm (1/8-1/4 in.)

# Carburetor Schematic

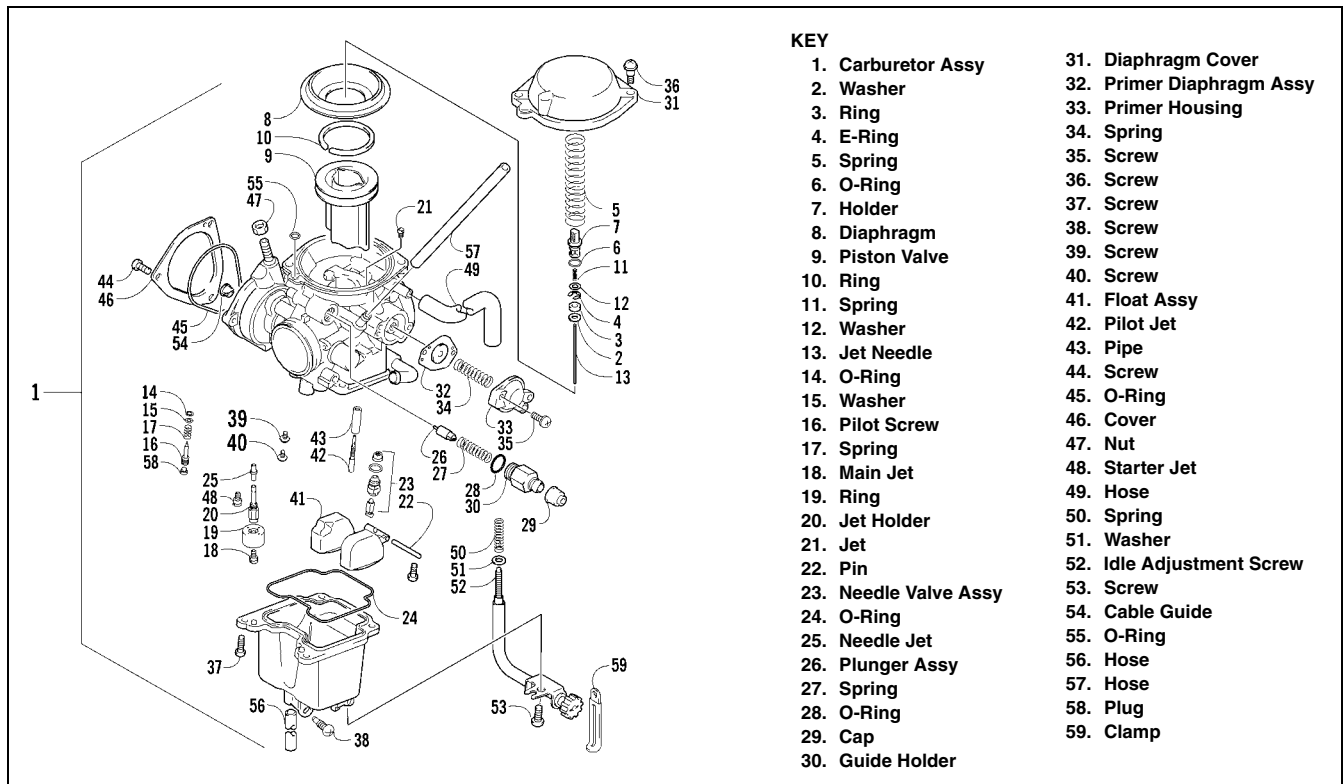

0739-211

---

---

# Carburetor

---

## WARNING

Whenever any maintenance or inspection is performed on the fuel system during which there may be fuel leakage, there should be no welding, smoking, open flames, etc., in the area.

■ **NOTE:** The fuel valve is an automatic-off diaphragm style. Fuel will flow only when the engine is being started or when it is running; however, in the prime position, fuel will flow unrestricted to the carburetor.

## REMOVING

1. Ensure the fuel valve is not in the PRI position.
2. Remove the seat.
3. Remove the air-intake snorkel.
4. Disconnect the hose from the carburetor to the gas tank at the fuel valve connection.
5. Loosen the flange clamps; then remove the carburetor from the two carburetor boots.
6. Remove the three screws securing the throttle actuator cover (5) to the carburetor; then remove the cover. Account for the O-ring (7).

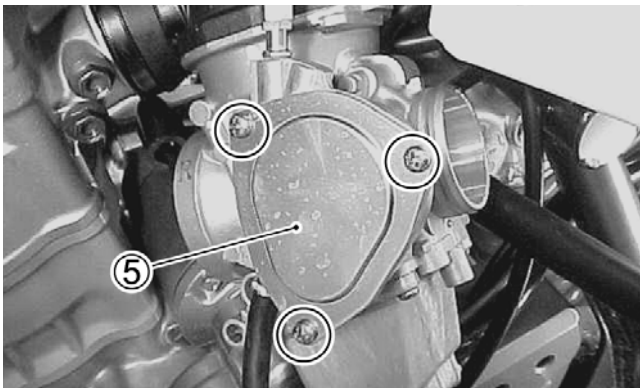

SP279

7. Disconnect the throttle cable from the actuator arm; then loosen the outer jam nut (6) securing the throttle cable to the carburetor body and route the cable out of the way.

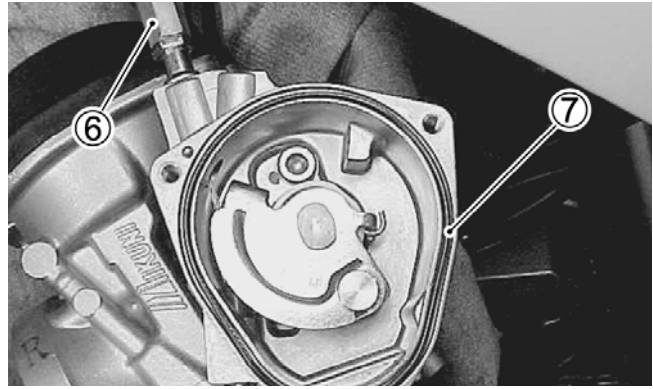

SP280

8. By unscrewing the choke cable end (4), disconnect the choke cable from the carburetor.

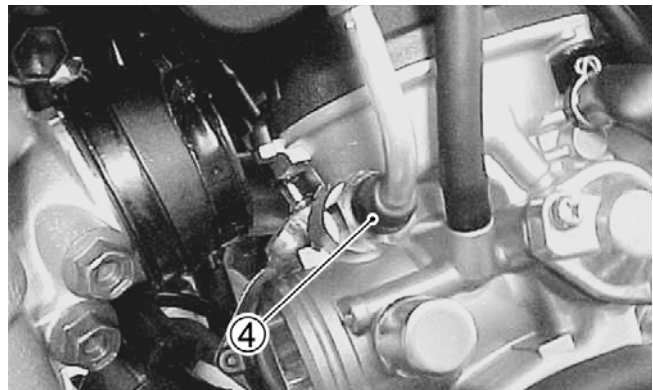

SP281

9. Disconnect the gas and vent hoses; then remove the carburetor.

## DISASSEMBLING

1. Remove the two Phillips-head screws securing the diaphragm cover; then remove the cover, spring (1), O-ring (2), and the diaphragm (3).

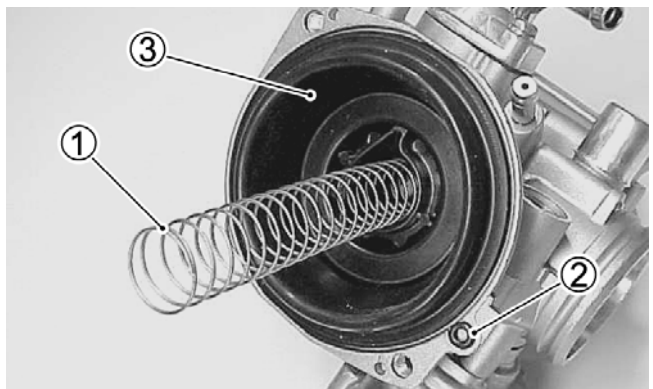

SP282

2. Remove the needle holder assembly from the diaphragm. Account for a spring, spring washer, and the jet needle.

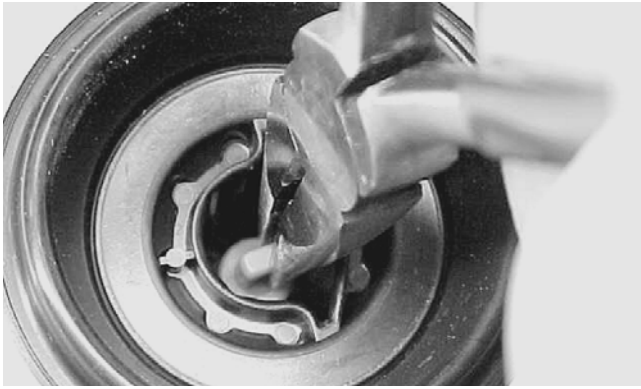

SP283

3. Remove the two screws securing the primer housing. Account for the primer diaphragm assembly (11) and spring.

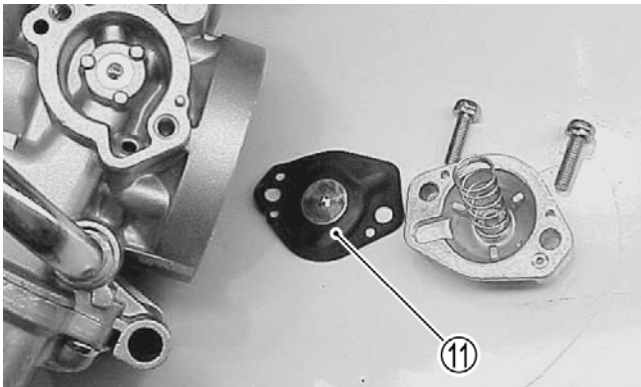

SP284

4. Remove the Phillips-head screws securing the float chamber; then remove the chamber. Account for the O-ring (12).



SP285

5. Remove the float pin (13); then lift the float assembly (14) from the carburetor. Account for the needle valve (15).

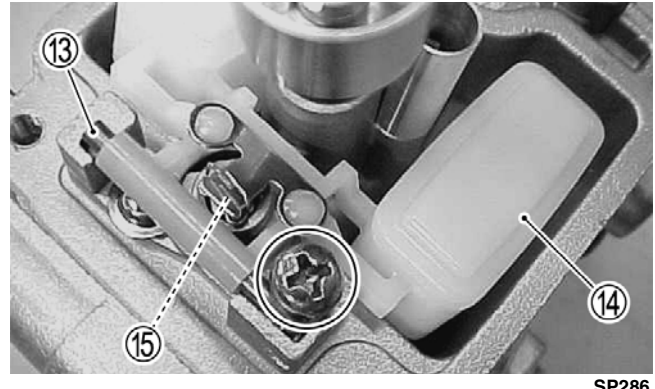

SP286

■ **NOTE:** Note the locations of the jets, pilot screw, and holder for disassembling procedures.

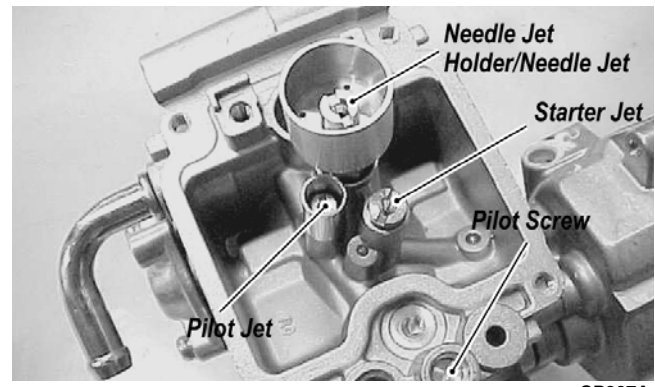

SP287A

6. Secure the needle jet holder with a wrench; then remove the main jet.
7. Remove the needle jet holder; then remove the pilot jet and the starter jet.
8. Remove and install the pilot air screw using the following procedure.
  - A. Using a 1/8-in. drill bit with a drill-stop (1) set at 4 mm (0.16 in.) from the end, drill through the plug (2).
  - B. Thread a self-tapping screw into the plug and use a pliers to pull the plug from the carburetor body (4).
  - C. Turn the pilot screw (3) clockwise counting the turns until it is lightly seated; then remove the pilot screw accounting for a spring, washer, and O-ring.



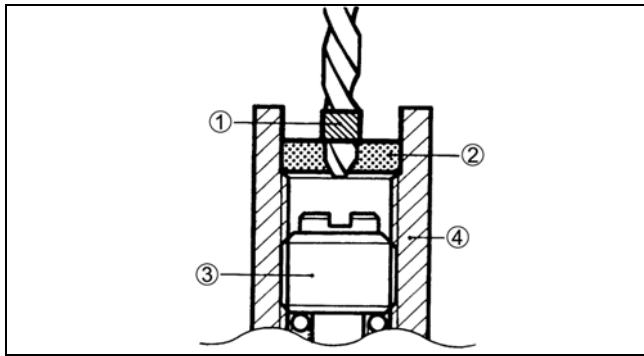

ATV2179

D. After cleaning, install the pilot screw (with a new O-ring) to the original position by turning in until it lightly seats; then turning it out the number of turns counted in step C.

E. Using an appropriate punch, tap a new plug into place.

9. Unscrew and remove the idle adjustment screw. Account for the spring and washer.

### AT THIS POINT

**Prior to assembling, the carburetor components should be cleaned and inspected (see Cleaning and Inspecting Carburetor sub-section).**

### ASSEMBLING

1. Screw the idle adjustment screw into the carburetor making sure the washer and spring are properly positioned.
2. Install the pilot jet (20). Tighten securely; then install the starter jet (19).
3. Install the main jet into the needle jet holder (17) and tighten securely; then install the needle jet holder assembly into the carburetor and tighten securely.

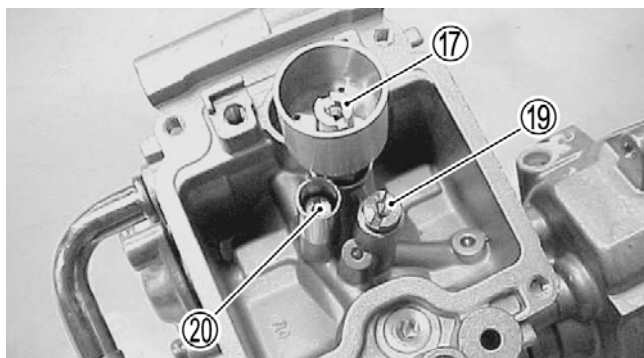

SP287B

4. Place the float assembly (with needle valve) into position and secure to the carburetor with the float pin.

■ **NOTE:** Check float arm height (A) by placing the carburetor on its side w/float contacting the needle; then measure with a caliper the height when the float arm is in contact with the needle valve. Float arm height should be 13 mm (0.5 in.).

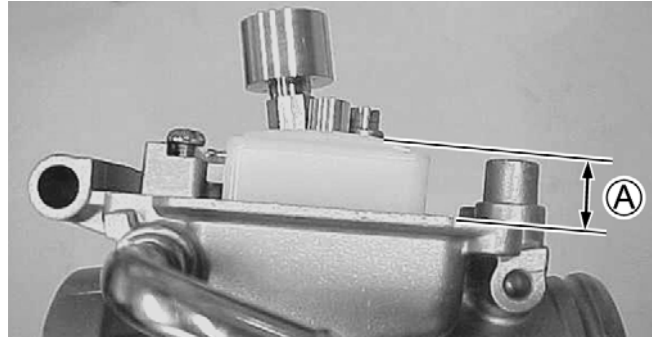

SP288

5. Place the float chamber into position making sure the O-ring is properly positioned; then secure with the Phillips-head screws.

6. Position the spring and primer diaphragm assembly (lip toward the carburetor) onto the carburetor; then secure the assembly with the primer housing and two screws. Tighten securely.

**4**

### CAUTION

**It is important to press down on the primer housing until it contacts the carburetor to make sure the diaphragm lip is properly seated in the groove in the carburetor. If the diaphragm is not properly seated, leakage will occur.**

7. Place the jet needle, spring seat, and spring into the piston valve; then place the assembly down into the carburetor.

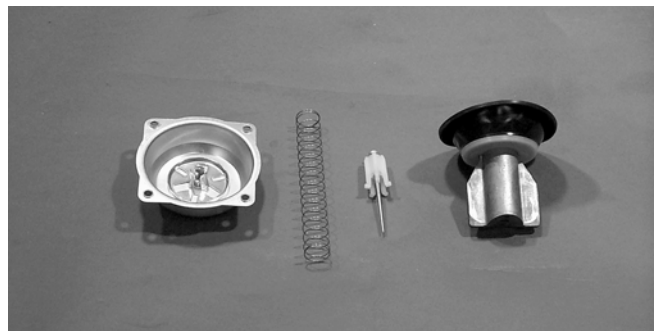

CC746

8. Place the diaphragm cover into position; then secure with the Phillips-head screws. Tighten securely.

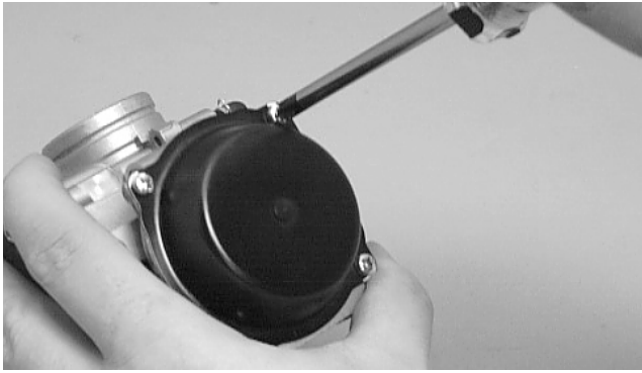

CH015D

## INSTALLING

1. Connect the gas and vent hoses onto the carburetor.
2. Connect the choke cable by screwing the choke cable end onto the carburetor.
3. Place the throttle cable into position and secure by tightening the outer jam nut.
4. Connect the throttle cable to the actuator arm.
5. Place the throttle actuator cover into position on the carburetor making sure the O-ring is properly positioned; then secure with three screws.
6. Position the carburetor in the air cleaner and intake pipe boots; then secure with the clamps.
7. Connect the hose at the fuel valve connection.
8. Secure the air-intake snorkel.
9. Install the seat and make sure it locks in position.

---

---

## Cleaning and Inspecting Carburetor

---

■ **NOTE:** Whenever a part is worn excessively, cracked, or damaged in any way, replacement is necessary.

### **WARNING**

When drying components with compressed air, always wear safety glasses.

### **CAUTION**

**DO NOT place any non-metallic components in parts-cleaning solvent because damage or deterioration will result.**

1. Place all metallic components in a wire basket and submerge in carburetor cleaner.
  2. Soak for 30 minutes; then rinse with fresh parts-cleaning solvent.
  3. Wash all non-metallic components with soap and water. Rinse thoroughly.
  4. Dry all components with compressed air only making sure all holes, orifices, and channels are unobstructed.
  5. Inspect the carburetor body for cracks, nicks, stripped threads, and any other imperfections in the casting.
  6. Inspect the piston valve/diaphragm for cracks, imperfections in the casting, or cracks and tears in the rubber.
  7. Inspect float for damage.
  8. Inspect gasket and O-rings for distortion, tears, or noticeable damage.
  9. Inspect tips of the jet needle, pilot screw, and the needle valve for wear, damage, or distortion.
  10. Inspect all jets for obstructions or damage.
- **NOTE:** If the pilot jet is obstructed, the mixture will be extremely lean at idle and part-throttle operation.
11. Inspect the carburetor mounting flange for damage and tightness.

---

---

## Throttle Cable Free-Play

---

1. Check throttle cable free-play at the lever; free-play should be 3-6 mm (1/8 - 1/4 in.).
2. To adjust, slide the rubber boot away from the adjuster located near the throttle lever. Loosen the jam nut and rotate the adjuster in the appropriate direction until proper free-play is attained. Tighten the jam nut against the adjuster; then slide the rubber boot over the adjuster.

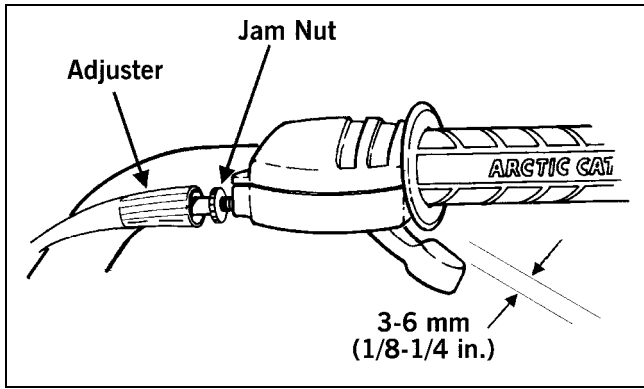

ATV-0047

## Engine RPM (Idle)

To properly adjust the idle RPM, a tachometer is necessary.

To adjust idle RPM, use the following procedure.

■ **NOTE:** The idle adjustment screw is located on the right-hand side of the carburetor.

1. Start the engine and warm it up to operating temperature.
2. Turn the idle adjustment screw clockwise or counterclockwise until the engine idles at 1250-1350 RPM.

### **⚠ WARNING**

**Adjust the idle to the correct RPM. Make sure the engine is fully warm before adjusting the idle RPM.**

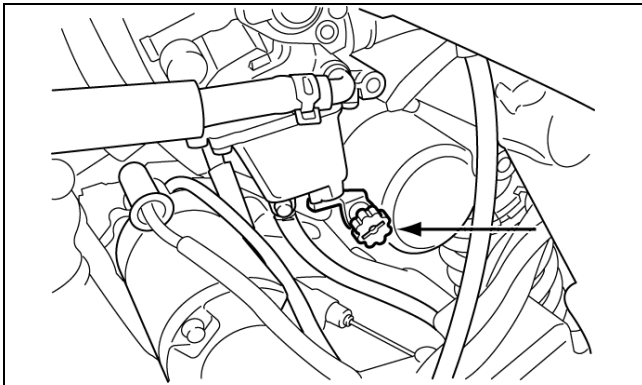

ATV2015A

## Gas Tank

### **⚠ WARNING**

Whenever any maintenance or inspection is made on the fuel system during which there may be fuel leakage, there should be no welding, smoking, open flames, etc., in the area.

■ **NOTE:** The fuel valve is an automatic-off diaphragm style. Fuel will flow only when the engine is being started or when it is running; however, in the prime position, fuel will flow unrestricted to the carburetor.

### REMOVING

1. Ensure that the fuel valve is not in the PRI position.
2. Remove the seat; then remove the gas tank.
3. Remove the body from the frame (see Section 8).
4. Disconnect the hose (1) from the carburetor to the gas tank at the tank connection; then disconnect the vacuum hose (2).

**4**

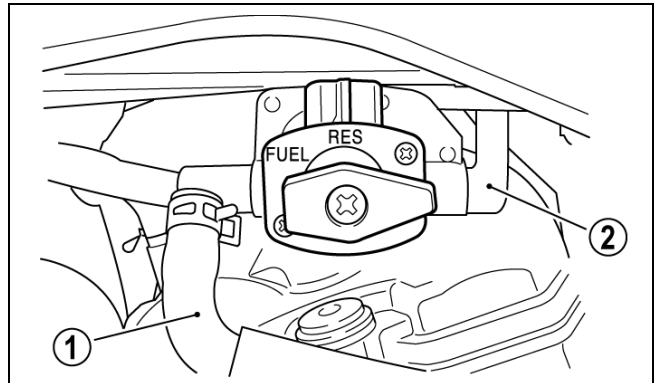

ATV2002A

5. Remove the cap screws securing the gas tank to the frame; then remove the air-intake snorkel (4).

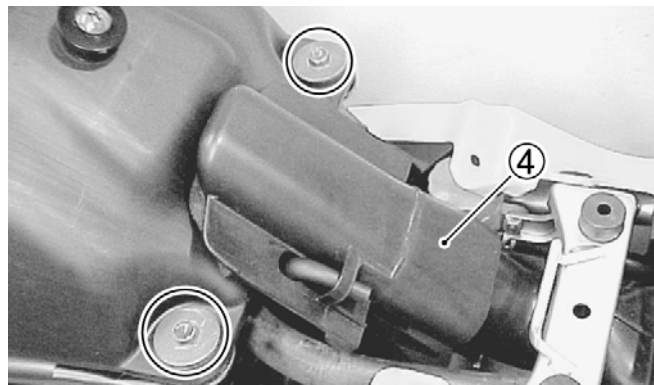

SP289

6. Remove the gas tank.

## CLEANING AND INSPECTING

■ **NOTE:** Whenever a part is worn excessively, cracked, or damaged in any way, replacement is necessary.

1. Clean all gas tank components with parts-cleaning solvent.
2. Inspect all hoses for cracks or leaks.
3. Inspect fuel valve, tank cap, and tank for leaks, holes, and damaged threads.

## INSTALLING

1. Place the gas tank into position on the frame; then install the cap screws. Tighten securely; then install the snorkel.
2. Connect the hose from the carburetor; then secure hose to cables and hoses with a cable tie.
3. Connect the vacuum hose to the fuel valve.
4. Install the vent hose; then fill the gas tank with gasoline.
5. Turn the fuel valve to the PRI position and inspect for leakage. Turn the fuel valve to the ON position after checking for leaks.
6. Install the body and secure the mounting brackets to the frame; then install the seat and make sure it locks securely.

---

---

## Fuel Valve

---

The fuel valve is on the gas tank. There are three positions: ON, RES (reserve), and PRI (primer).

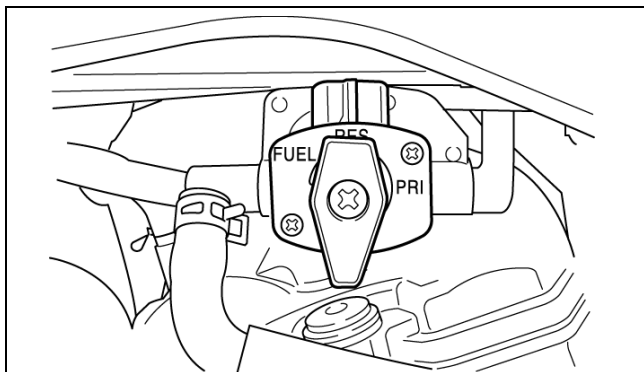

ATV2014

In the PRI position, the valve will allow gasoline to flow unrestricted to the carburetor. In the ON position (the normal operating position), gasoline will flow from the tank to the carburetor when the engine is being started or when it is running. In this position, 0.7 L (0.18 U.S. gal.) will remain in the tank as a reserve quantity.

Moving the valve to the reserve (RES) position will allow the operator to use the remaining gasoline in the tank. When turning the valve to any of the three positions, be sure the indicator is pointed directly at the position desired.

■ **NOTE:** The fuel valve is an automatic-off diaphragm style. Fuel will flow only when the engine is being started or when it is running; however, in the prime position, fuel will flow unrestricted to the carburetor.

### **WARNING**

Leaving the fuel valve in the “PRI” position when the engine is off can be hazardous. The carburetor may overflow and fuel may run into the engine. This can cause a fire or cause severe damage to the ATV when the engine is started. Always leave the fuel valve in the “ON” or “RES” position when the engine is not running.

## REMOVING/INSPECTING

### **WARNING**

Drain the gas tank prior to this procedure.

1. Remove the hose from the fuel valve by releasing the spring clamp; then remove the vacuum hose.
2. Remove the two nuts securing the fuel valve; then remove the valve. Account for the gasket.
3. Inspect the gasket and fuel valve/tank mating surfaces for damage or deterioration.
4. Inspect for and remove any obstructions in the valve.

## INSTALLING

1. Place the fuel valve and gasket into position on the tank and secure with the cap screws. Tighten to specifications.
2. Install the hose onto the fuel valve with the spring clamp; then connect the vacuum hose.

---

---

## Gas/Vent Hoses

---

Replace the gas hose every two years. Damage from aging may not always be visible. Do not bend or obstruct the routing of the carburetor vent hose. Make certain that the vent hose is securely connected to the carburetor and the opposite end is always open.





---

---

## Oil Filter/Oil Pump

---

■ **NOTE:** Whenever internal engine components wear excessively or break and whenever oil is contaminated, the oil pump should be disassembled, cleaned and inspected, and serviced as necessary.

### KEY

- |                       |               |
|-----------------------|---------------|
| 1. Oil Pump Assy      | 12. Cap       |
| 2. Driven Gear        | 13. O-Ring    |
| 3. Alignment Pin      | 14. Spring    |
| 4. Washer             | 15. Cap Screw |
| 5. Circlip            | 16. Spring    |
| 6. Screw              | 17. Ball      |
| 7. Inner/Outer Rotors | 18. Seat      |
| 8. Strainer           | 19. Idle Gear |
| 9. Cap Screw          | 20. Shaft     |
| 10. Filter            | 21. Circlip   |
| 11. O-Ring            |               |

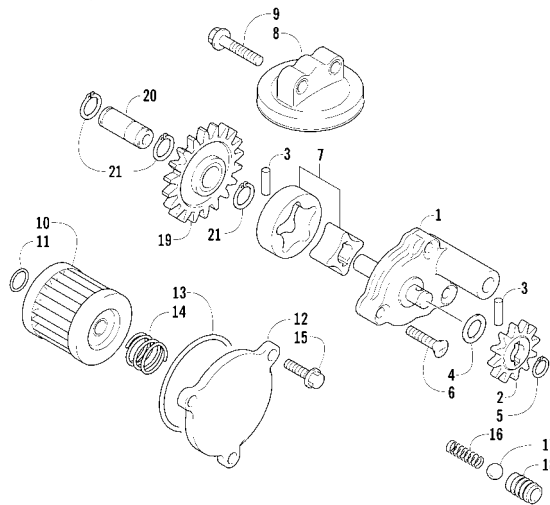

0739-215

### REMOVING/DISASSEMBLING

1. Remove the oil pump from the engine (see Section 3 - Right-Side Components).
2. Disassemble oil pump components. Note the position of the inner and outer rotors and alignment pin for assembly.

### CLEANING AND INSPECTING

■ **NOTE:** Whenever a part is worn excessively, cracked, or damaged in any way, replacement is necessary.

1. Clean all oil-pump components.
2. Inspect the rotors for scoring and gouges.
3. Inspect the alignment pin for damage.

4. Inspect the pump housing for cracks or damage.

### ASSEMBLING/INSTALLING

1. Place the rotors into the pump housing making sure the alignment pin is in the groove of the rotor.
2. Install the oil pump into the engine (see Section 3 - Right-Side Components).

---

---

## Testing Oil Pump Pressure

---

■ **NOTE:** The engine must be warmed up to operating temperature for this test.

1. Connect the Arctic Cat Engine Tachometer (p/n 0644-275) to the engine.
2. Remove the oil galley plug; then connect the Oil Pressure Gauge (p/n 0444-039) to the galley using an appropriate adapter.

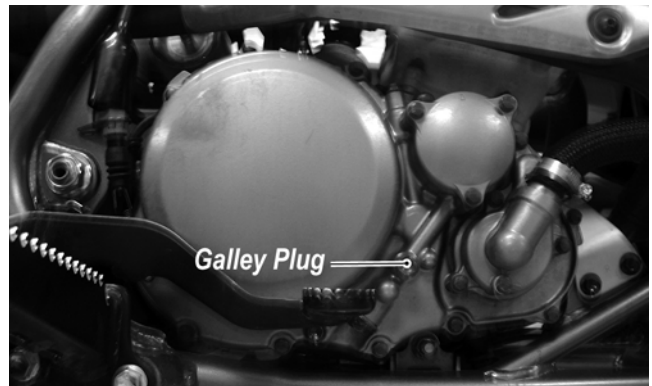

SP004A

■ **NOTE:** Some oil seepage may occur when installing the oil pressure gauge. Wipe up oil residue with a cloth.

3. Start the engine and run at the specified RPM.
4. The oil pressure gauge must read 0.2 kg-cm<sup>2</sup> (2.8 psi) - 0.6 kg-cm<sup>2</sup> (8.5 psi).

■ **NOTE:** If the oil pressure is lower than specified, check for an oil leak, damaged oil seal, or a defective oil pump.

■ **NOTE:** If the oil pressure is higher than specified, check for too heavy engine oil weight (see Section 2), clogged oil passage, clogged oil filter, or improper installation of the oil filter.

---

---

# Oil Tank

---

## REMOVING

1. Remove the seat; then remove the fasteners securing the body to the frame and remove the body. See Section 8.
2. Drain the engine coolant; then remove the radiator (see Radiator in this section).
3. Drain the engine oil from the tank and remove the oil tank protector (1).

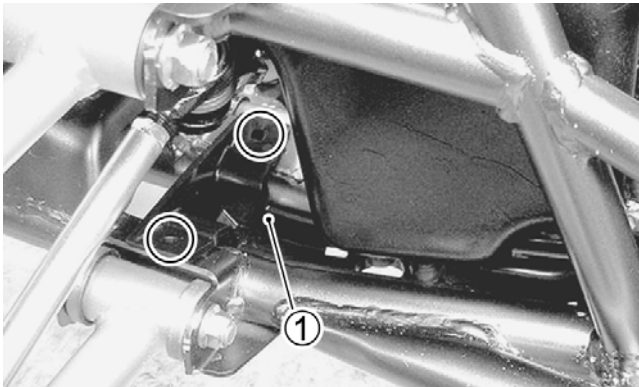

SP290

4. Remove the oil lines from the tank. Account for the two O-rings (7) and two alignment pins (8).

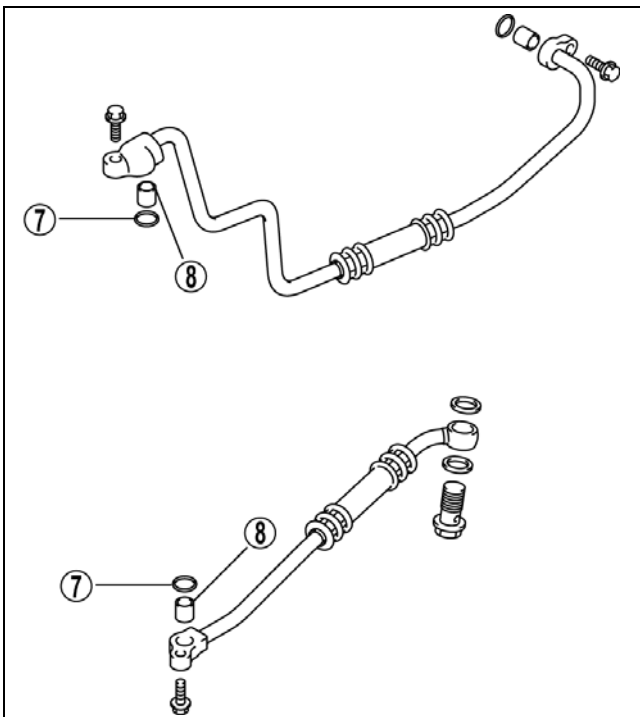

ATV2181A

5. Remove the cap screws securing the tank to the frame; then remove the overflow hose and remove the tank. Account for the tank mounting isolators and two spacers.

■ **NOTE:** If the tank isolators are oil soaked or damaged, new ones should be installed.

## INSTALLING

1. Ensure that the tank mounting isolators are serviceable; then install the tank onto the frame and tighten the cap screws securely.

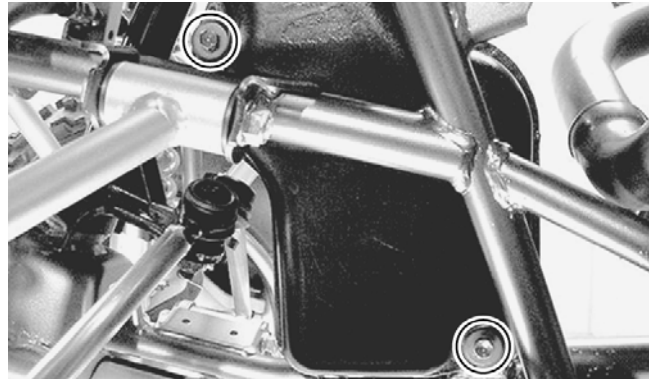

SP291

2. Install new O-rings to the upper and lower tank fittings; then secure the fittings to the tank and tighten the cap screws securely. Install the overflow hose.

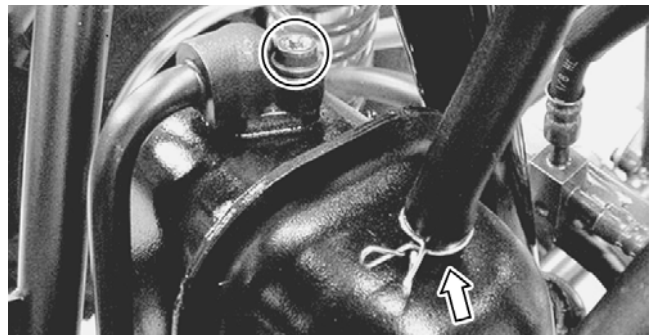

SP292



SP293

3. Fill the oil tank with the correct amount of recommended engine oil. See Section 2.
4. Install the radiator (see Radiator in this section) and fill the cooling system.
5. Install the body (see Section 8); then install the seat.
6. Start the engine and check for coolant or oil leaks; then recheck the proper coolant and oil levels. See Section 2.

4

# Liquid Cooling System

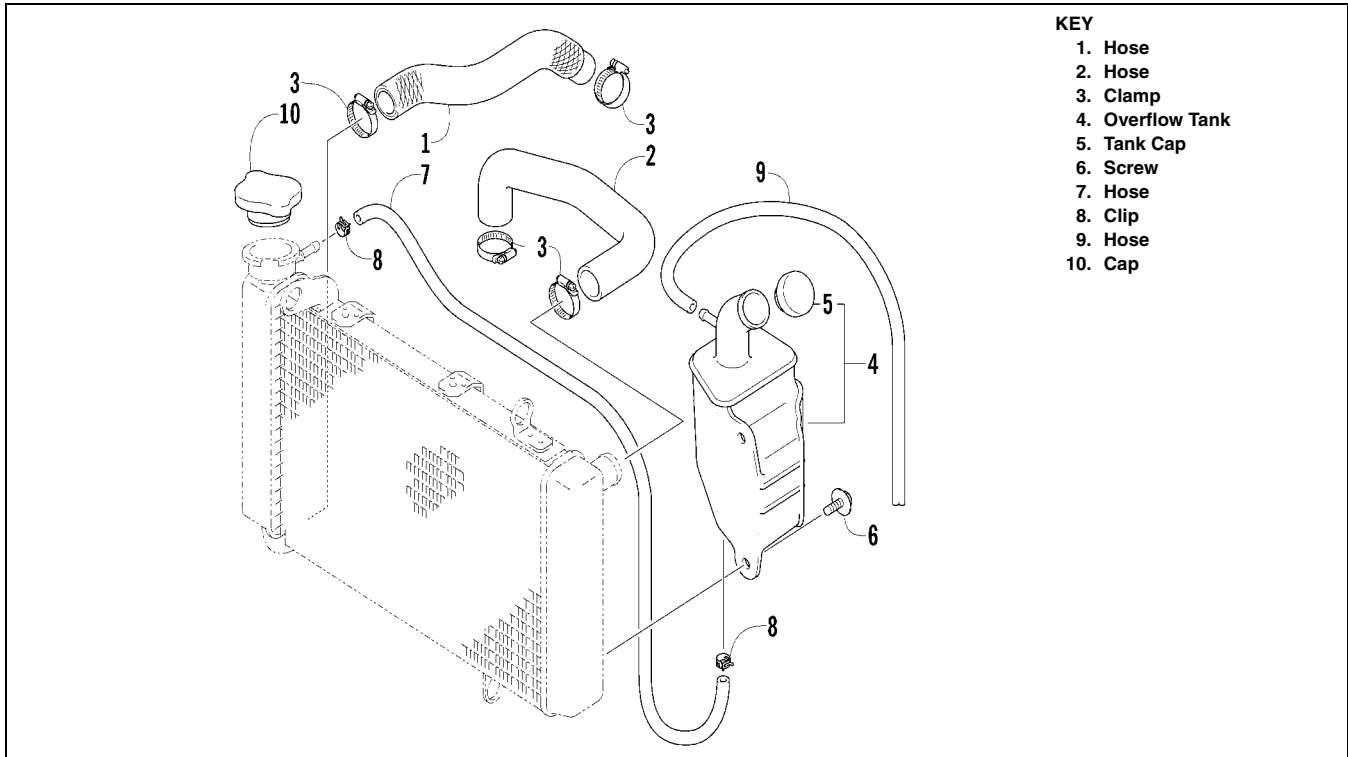

- KEY**
- 1. Hose
  - 2. Hose
  - 3. Clamp
  - 4. Overflow Tank
  - 5. Tank Cap
  - 6. Screw
  - 7. Hose
  - 8. Clip
  - 9. Hose
  - 10. Cap

0739-224

The cooling system capacity is approximately 1.2 L (1.3 U.S. qt). The cooling system should be inspected daily for leakage and damage. Also, the coolant level should be checked periodically.

When filling the cooling system, use premixed Arctic Cat Antifreeze (p/n 0638-395). While the cooling system is being filled, air pockets may develop; therefore, run the engine for five minutes after the initial fill, shut the engine off, and then fill the cooling system to the bottom of the stand pipe in the radiator neck.



AN604D

## CAUTION

After operating the ATV for the initial 5-10 minutes, stop the engine, allow the engine to cool down, and check the coolant level. Add coolant as necessary.

# Radiator

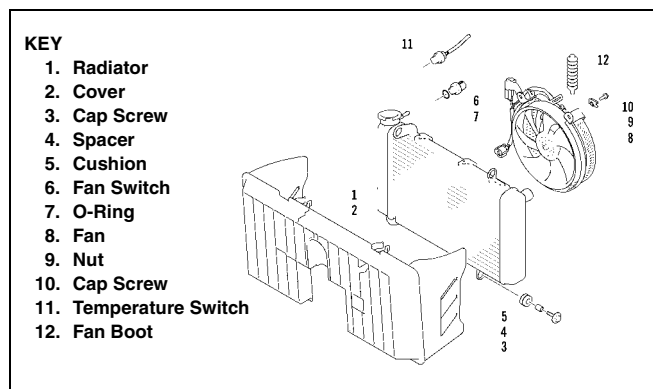

- KEY**
- 1. Radiator
  - 2. Cover
  - 3. Cap Screw
  - 4. Spacer
  - 5. Cushion
  - 6. Fan Switch
  - 7. O-Ring
  - 8. Fan
  - 9. Nut
  - 10. Cap Screw
  - 11. Temperature Switch
  - 12. Fan Boot

0739-218

## REMOVING

1. Drain the coolant from the engine; then remove the seat and body (see Section 8).
2. Disconnect the negative battery cable; then disconnect the positive cable.
3. Remove the front bumper (see Section 8).
4. Remove the upper and lower coolant hoses.



5. Remove the cap screws and nuts securing the radiator to the frame.
6. Disconnect the fan wiring from the main wiring harness; then remove the radiator/fan assembly and account for the cushions and spacers.
7. Remove the fan assembly from the radiator.

## CLEANING AND INSPECTING

■ **NOTE:** Whenever a part is worn excessively, cracked, or damaged in any way, replacement is necessary.

1. Flush the radiator with water to remove any contaminants.
2. Inspect the radiator for leaks and damage.
3. Inspect all hoses for cracks and deterioration.
4. Inspect all fasteners and cushions for damage or wear.

## INSTALLING

1. Position the fan assembly on the radiator; then secure with existing hardware.
2. Place the radiator with cushions and spacers into position on the frame; then install the cap screws and nuts. Tighten securely.
3. Install the upper and lower coolant hoses; then secure with hose clamps.
4. Install the front bumper (see Section 8).
5. Fill the cooling system (1.2 L or 1.3 U.S. qt) with antifreeze. Check for leakage.
6. Connect the fan wiring to the main wiring harness. Install the body and seat (see Section 8).

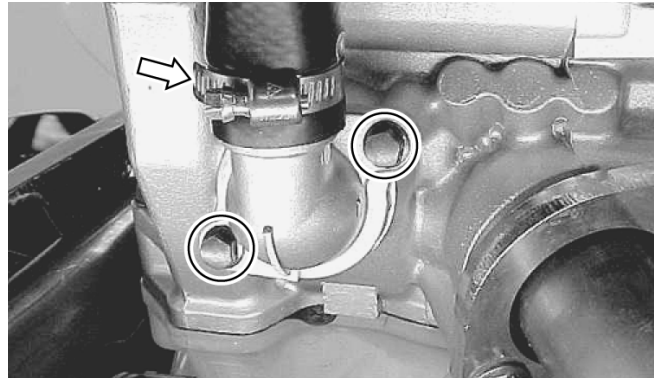

SP294

## INSPECTING

■ **NOTE:** Whenever a part is worn excessively, cracked, or damaged in any way, replacement is necessary.

1. Inspect the thermostat for corrosion, wear, or spring damage.
2. Using the following procedure, inspect the thermostat for proper operation.
  - A. Suspend the thermostat in a container filled with water.
  - B. Heat the water and monitor the temperature with a thermometer.
  - C. The thermostat should start to open at 75°C (167°F).
  - D. If the thermostat does not open, it must be replaced.
3. Inspect all coolant hoses, connections, and clamps for deterioration, cracks, and wear.

■ **NOTE:** All coolant hoses and clamps should be replaced every four years.

## INSTALLING

1. Place the thermostat into the thermostat housing; then secure the thermostat housing to the cylinder head with the two cap screws.
2. Slide the upper hose onto the thermostat housing; then secure with the hose clamp.
3. Fill the cooling system (1.2 L or 1.3 U.S. qt) with antifreeze. Check for leakage.

---



---

# Hoses/Thermostat

---

## REMOVING

1. Drain the coolant from the cooling system.
2. Remove the hose clamp securing the upper coolant hose to the thermostat housing; then remove the thermostat housing and the thermostat.

---

---

## Fan

---

### REMOVING

1. Remove the cooling fan assembly from the radiator.

### INSTALLING

1. Position the fan assembly on the radiator; then secure with existing hardware.

---

---

## Servicing Water Pump

---

### KEY

- |                       |                 |
|-----------------------|-----------------|
| 1. Water Pump Housing | 10. Drain Plug  |
| 2. Impeller/Shaft     | 11. Gasket      |
| 3. Mechanical Seal    | 12. Cap Screw   |
| 4. Oil Seal           | 13. Cap Screw   |
| 5. Bearing            | 14. O-Ring      |
| 6. E-Ring             | 15. Circlip     |
| 7. O-Ring             | 16. Driven Gear |
| 8. Case               | 17. Washer      |
| 9. O-Ring             | 18. Pin         |

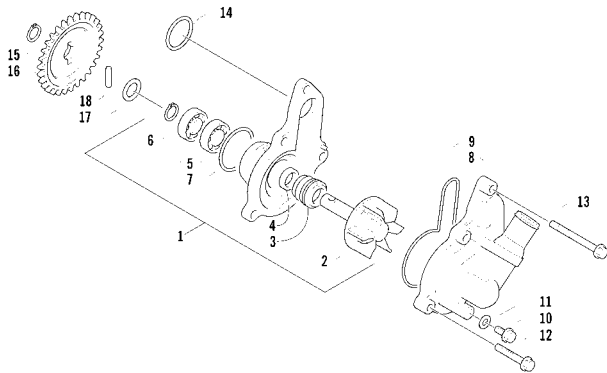

0739-217

### REMOVING

1. Drain the engine coolant and engine oil; then disconnect the radiator hose.

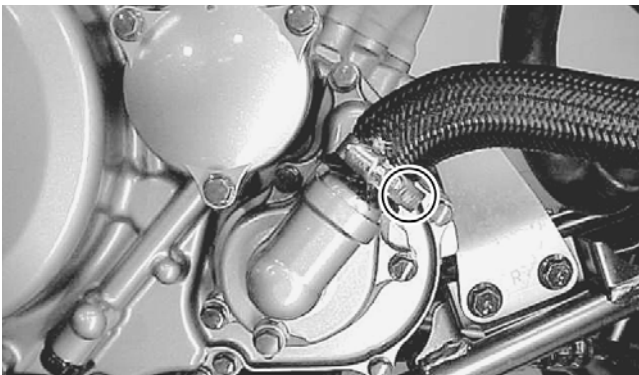

SP295

2. Disconnect the rear brake switch spring and brake pedal spring; then remove the master cylinder mounting bolts.



SP296



SP297

3. Remove the cap screws securing the clutch cover; then depress the brake pedal and remove the clutch cover.

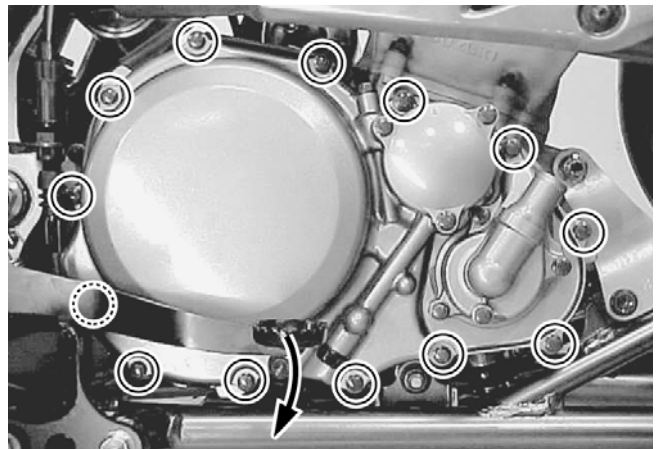

SP298

4. Remove the water pump case; then remove the circlip (1), water pump driven gear (2), drive pin (3), and washer (4).

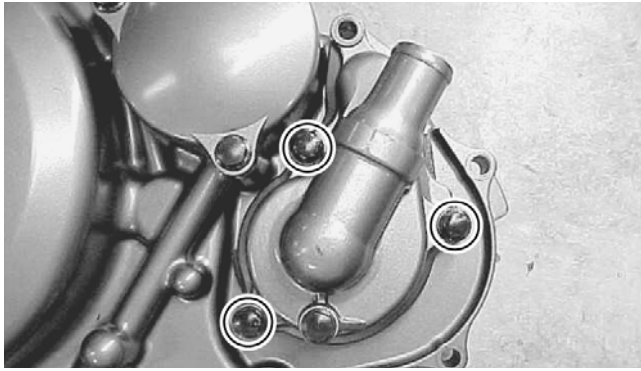

SP299

## CLEANING AND INSPECTING

■ **NOTE:** Whenever a part is worn excessively, cracked, or damaged in any way, replacement is necessary.

1. Clean all oil-pump components in cleaning solvent.
2. Inspect the impeller/shaft for corrosion or damage.

## ASSEMBLING

1. Place the new oil seal into the housing; then using a seal driver, gently tap the seal down until it is fully seated.

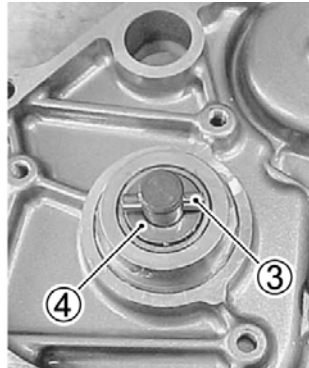
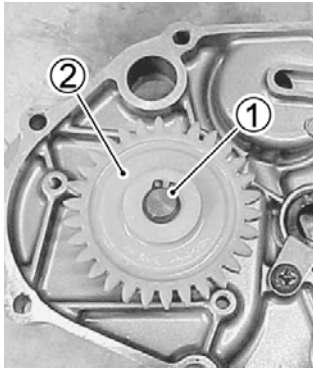

SP300A



SP304

## DISASSEMBLING

1. Remove the E-ring (5) securing the impeller/shaft to the housing (7); then remove the impeller/shaft (6).

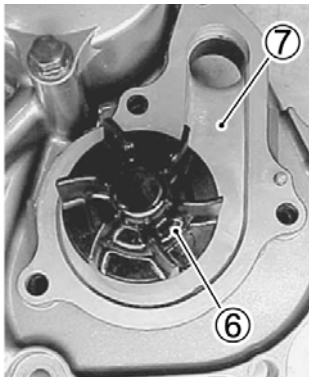

SP302A

2. Using Seal Removal Tool (p/n 0644-072), remove the mechanical seal and the oil seal.

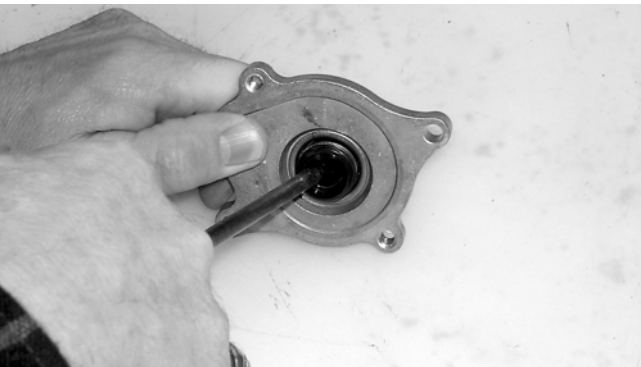

CC772

■ **NOTE:** A large, deep socket can be used to drive the seal down evenly.

3. Install new O-rings in the water pump housing; then install the water pump with impeller into the clutch cover.

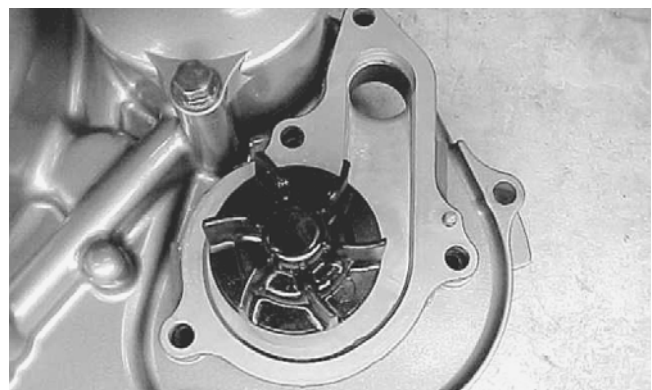

SP305

4. Install the E-ring on the impeller shaft making certain it is properly seated.



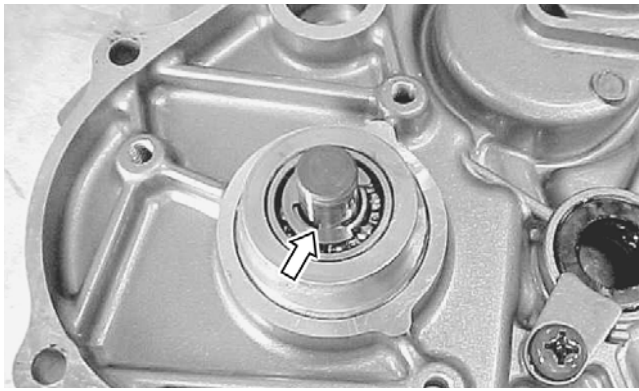

SP306

5. Install the washer (1), drive pin (2), and driven gear (3); then install the circlip (4). Make sure the circlip is properly seated.

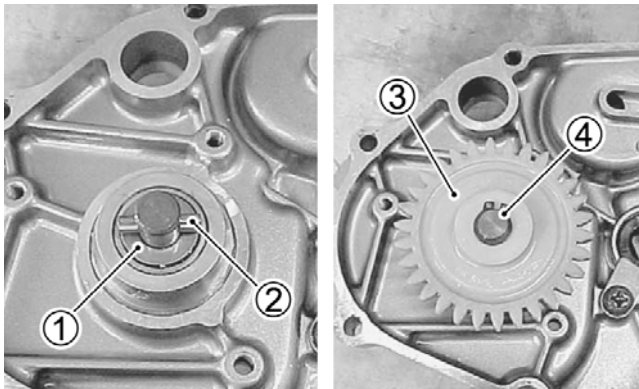

SP307A

## INSTALLING

1. Install a new O-ring in the water pump case; then attach the case to the clutch cover.

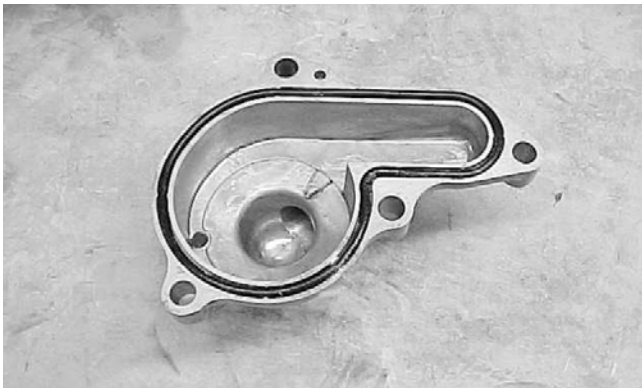

SP309

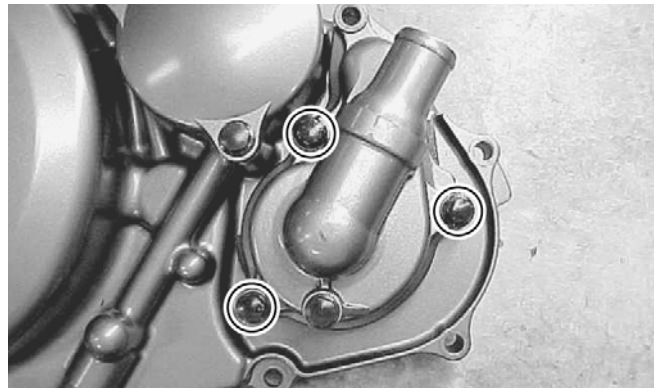

SP310

2. Install the clutch cover and tighten the cap screws securely; then install the master cylinder mounting bolts and tighten to specifications.

3. Connect the brake switch spring and the brake pedal spring.

4. Connect the radiator hose; then fill the cooling system with the recommended amount of coolant.



AN604D

■ **NOTE:** While the cooling system is being filled, air pockets may develop; therefore, run the engine for five minutes after the initial fill, shut the engine off, and then fill the cooling system.

5. Refill the engine oil tank; then run the engine for several minutes and check for leaks. Recheck the engine oil and coolant levels.

6. Check the entire cooling system for leakage.

### CAUTION

After operating the ATV for the initial 5-10 minutes, stop the engine, allow the engine to cool down, and check the coolant level. Add coolant as necessary.



---

---

## Engine Coolant Temperature Switch

---

### REMOVING

1. Drain the coolant in the radiator to a point below the upper temperature switch.
2. Disconnect the engine coolant temperature lead wire coupler (1); then remove the engine coolant temperature switch (2).



SP311

■ **NOTE:** For complete testing procedures for the coolant temperature switch, see Section 5.

### INSTALLING

1. Apply engine coolant to the O-ring; then install the engine coolant temperature switch and tighten to specifications.
2. Connect the lead wire coupler; then fill the cooling system with recommended coolant.
3. Start the engine and check for coolant leaks; then shut the engine off and check coolant level in the overflow tank. Coolant should be between upper and lower level marks.

---

---

## Cooling Fan Thermo-Switch

---

### REMOVING

1. Drain the coolant in the radiator to a point below the lower temperature switch.
2. Disconnect the cooling fan thermo-switch lead wire coupler (1); then remove the cooling fan thermo-switch (2).

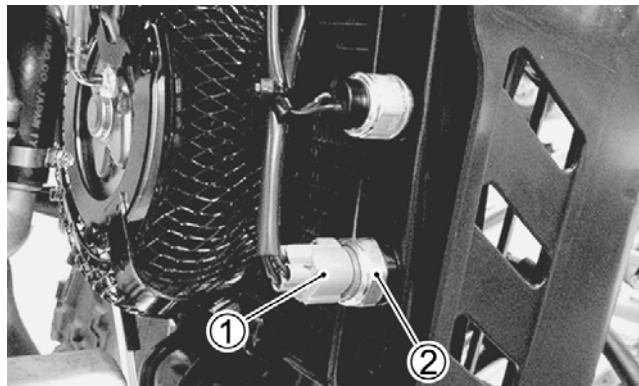

SP312

■ **NOTE:** For complete testing procedures for the cooling fan thermo-switch, see Section 5.

### INSTALLING

1. Apply engine coolant to the O-ring; then install the cooling fan thermo-switch and tighten to specifications.
2. Connect the lead wire coupler; then fill the cooling system with recommended coolant.
3. Start the engine and check for coolant leaks; then shut the engine off and check coolant level in the overflow tank. Coolant should be between upper and lower level marks.

4

# NOTES